

# Lo-Watt Domestic Heat Recovery Units

## The Windsor Range



MANHR100



### Features & Benefits

- Installation in bathrooms/WC's.
- Meets building regulations for Bathrooms and Toilets for system 1 intermittent extract and for constant ventilation as per system 4 requirement.
- Eliminates mould.
- Controls condensation.
- 70% Heat Recovery.

### Technical Details

Model No.	Product type
MANHR100W	Std Heat Recovery Unit
MANHR1345	Boost Switch

### Performance

	HR100W	
Extract Performance m <sup>3</sup> /hr	High	77
	Low	43
Intake Performance m <sup>3</sup> /hr	High	69
	Low	38
Watts	High	31
	Low	12
Sound dB(A) at 3m	High	35
	Low	20

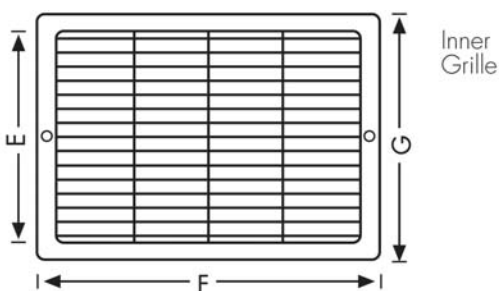
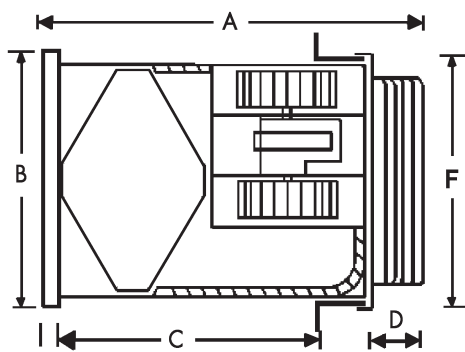

### Dimensions:

A	B	C	D	E	F	G	Weight
370	270	220-280	68	155	235	190	4.85

